

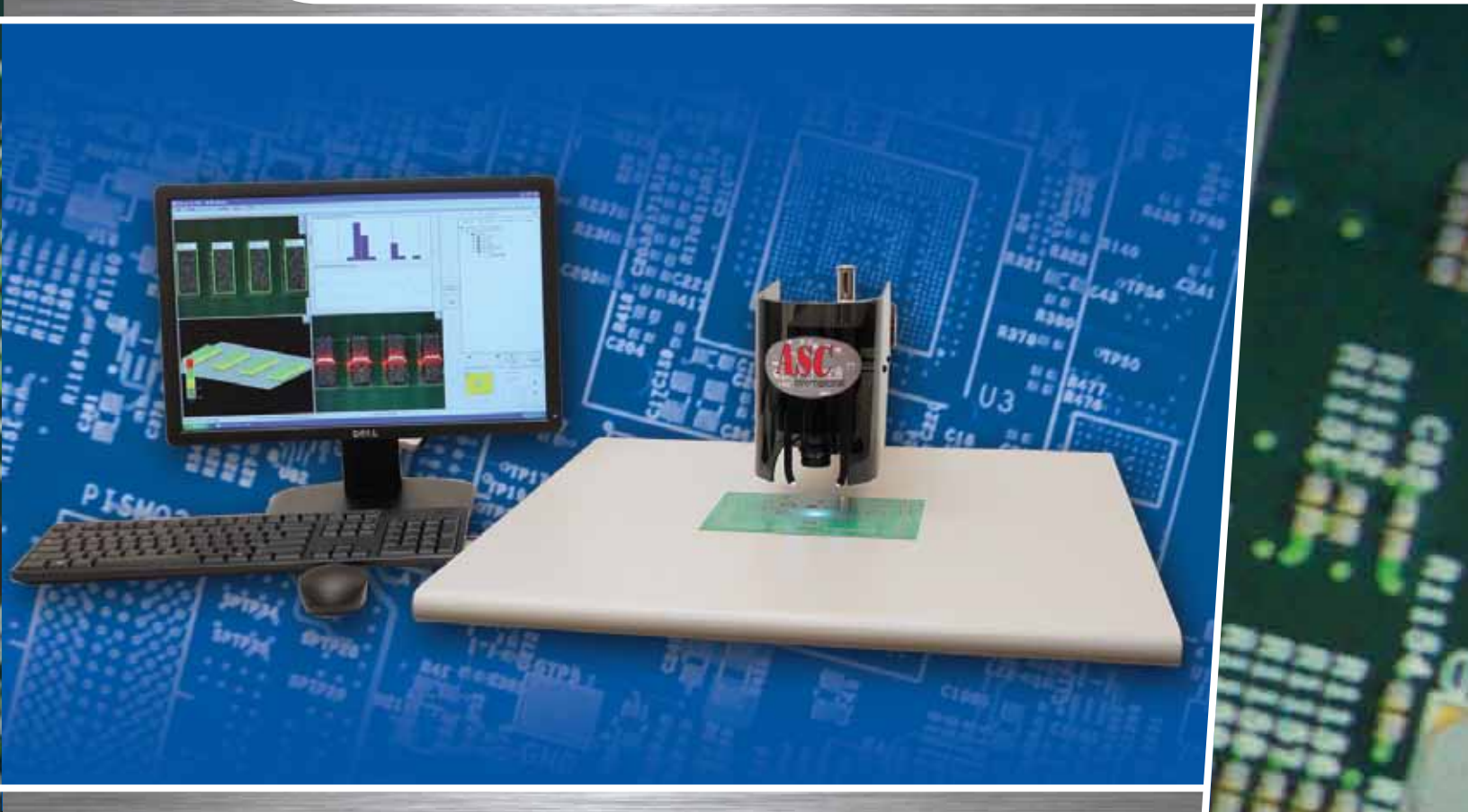

PRODUCT DESCRIPTION AND SPECIFICATIONS

LaserVision SP3D Mini

3D SOLDER PASTE INSPECTION



LaserVision SP3D Mini provides a powerful alternative to visual inspection of solder paste deposits, automatically calculating and storing critical printing characteristics in one click. Using a lower cost microscope platform, LaserVision SP3D Mini enables ASC International to offer the same remarkable SPI technology found in their VisionPro and VisionPro AP Series models, but in an entry-level instrument. This makes LaserVision SP3D Mini ideal for manufacturers striving for better process control of the paste printing process, but working with a limited budget.

System Features: Automatic Calculation of Height, Width, Area and Volume Measurements
• Four Unique and Flexible Operating Modes • Fully Integrated Real Time SPC Run Charts and Histograms • Customized Data Reports with Data Tag Traceability • Simple USB Interface for Service Free Maintenance • One Year Warranty • Accurate and Repeatable Measurements of Solder Paste, Adhesives, Grease and More!

Automated Measurements

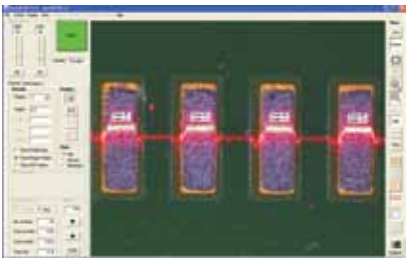

To obtain automated measurements on the **SP3D Mini**, position the circuit board under the system's laser-based vision sensor to the desired location. Simply click the large green run button to automatically calculate the solder paste height, width, area and volume. Automated measurements reduce the errors associated with operator to operator variations.

3D Scanning Laser

The **SP3D Mini's** optional laser scanning feature provides 3D profiling capabilities along with added accuracy and repeatability due to increased data acquisition. This feature also provides a second layer of analysis to establish proper corrective actions based upon qualitative defect attributes.

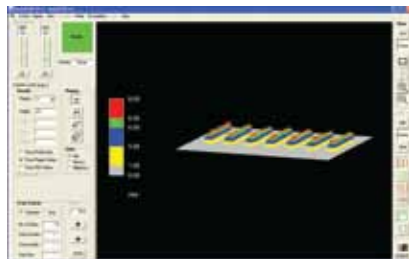

Onboard SPC Features

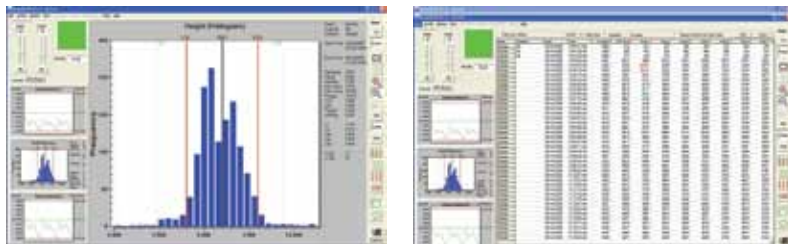

Customized Data Reports

The onboard SPC interface is a powerful tool that helps operators control the critical parameters of the stencil printing process. Data collected is instantly charted by the integrated SPC software. Calculations crucial to the printing performance are managed by the following information:

- User Defined LSL, Target and USL
- X-bar / R and Histogram Charting
- Min / Max / Median Values
- Cp / Cpk / Cr and Lower Z Value

LaserVision SP3D Mini System includes:

- Windows® OS • Dell 2.5+ Ghz CPU with 20" + LCD Monitor • High Resolution CMOS Color Camera and Class II Laser • Anti-static Work Surface
- Hardware/Software Reference Manuals • 12 Month Warranty with Free On-line Technical/Training Sessions.

System Options:

- Laser Scanning Module for Producing 3D Profiles • NIST Calibration Tool
- Extended Warranty Options.

MECHANICAL SPECIFICATIONS

LaserVision SP3D Mini

General System Specifications

Maximum Object Thickness:	5.1 cm (2.0")
Standard Work Surface:	61 x 61 cm (24" x 24")
Throat Depth	
(Sensor to Rear Support):	22 cm (8.5")
System Computer:	2.5 + Ghz CPU, 1.0 GB RAM, Windows® OS
Electrical Requirements:	100 - 240 VAC, 50 - 60 Hz, 2 Amps
Ambient Operating Temperature:	5 °C - 38 °C (40 °F - 100 °F)
Ambient Operating Humidity:	<90 % Non-condensing
System Weight:	18 Kg (40 lbs.)
Crated System Weight:	40 Kg (88 lbs.)
Measurement Capability:	Height, Width, Area & Volume Measurements
SPC Charting/ Data Reports:	Integrated
Work Instructions:	Built-in

Sensor Specifications

Measurement Principle:	Laser Technology
Camera (Pixel):	1280 x 1024
Lateral Resolution:	3.5 µm (0.14 mils)
FOV Size:	4.8 x 3.6 mm (186 x 142 mils)
Z Resolution:	2.5 µm (0.1 mil)
Measurement Range:	2.5 mm (100 mils)
Illumination:	LED White Light with Laser

Inspection Performance

Inspection Speed:	60 Frames/sec.
Static Repeatability:	2.5 µm (0.1 mil)
Gauge R&R (±50% tolerance on PCB):	<10 %
Height Accuracy on Calibration Tool:	2 µm (0.8 mils)
Minimum Paste Deposit Size:	127 µm (5 mils)

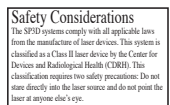
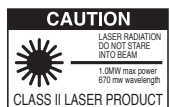
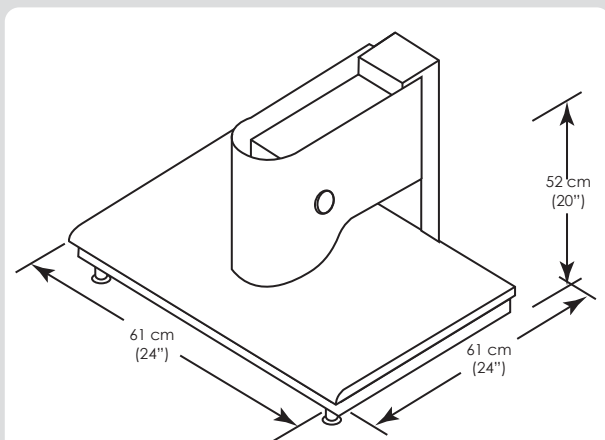

For More Information:

ASC International
830 Tower Drive
Medina, MN 55340 U.S.A.

Toll Free: **1-888-478-2912 (USA ONLY)**
Tel: USA 763-479-6210
Fax USA 763-479-6206

E-mail: info@ascinternational.com
Web: www.ascinternational.com
www.solderpasteinspection.com

